

<b>INSTALLATION/ASSEMBLY TIPS</b>
<b>FREE STANDING BALLET BARRE INSTALLATION (PAGE 1 OF 2)</b>
<b>READ THIS DOCUMENT AND ALL OTHER ACCOMPANYING PRODUCT DOCUMENTATION THOROUGHLY BEFORE INSTALLING, USING OR PERMITTING USE OF THIS EQUIPMENT. REQUIRE ALL PERSONS INTENDING TO USE THIS EQUIPMENT, AS WELL AS THOSE INSTRUCTING, ASSISTING OR COACHING OTHERS IN THE USE OF THIS PRODUCT, TO READ THIS DOCUMENT THOROUGHLY BEFORE AUTHORIZING THEM TO ENGAGE IN THOSE OR RELATED ACTIVITIES.</b>

**NOTE: THESE INSTRUCTIONS ARE FOR 4', 6' 8' AND 10' FREE STANDING BARRES ONLY! SEPARATE INSTRUCTIONS ARE AVAILABLE FOR 14' AND LARGER FREE STANDING BARRES.**

**1. PARTS LIST**

SINGLE SIDE UNIT	DOUBLE SIDE UNIT
One Wood Barre	Two Wood Barre
One Large Folding X-Brace	One Large Folding X-Brace
Two 41" Long Uprights	Two 41" Long Uprights
Two 30" Long Legs	Two 30" Long Legs
Two 9" Extension Studs	Four 9" Extension Studs
Two Large Wing Nuts	Four Large Wing Nuts
Two Square Nuts And Two Washers	Four Square Nuts And Four Washers
Four Bolts And Four Wing Nuts	Four Bolts And Four Wing Nuts

**1. ASSEMBLE BASE**

- a. Bolt legs to uprights.
- b. Unfold X-brace and fasten ends to studs on each upright with wing nuts.
- c. Base should look like this:

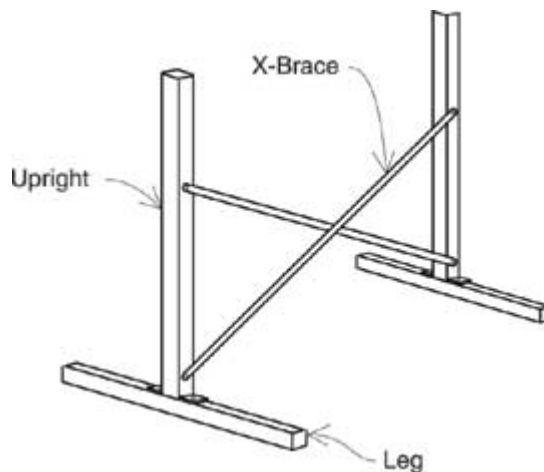

**⚠ IMPORTANT CONSUMER PRODUCT HAZARD WARNING — PLEASE READ!**

A possibility of serious injury, including paralysis or death, is inherent in any activity involving motion or height. Equipment with which this notice is included is intended for use only by properly trained, qualified persons under supervised conditions. Use without proper supervision is dangerous and should not be undertaken or permitted. Know your limitations as well as the limitations of your equipment. Consult a qualified instructor before attempting any new activity or skill. This equipment must be used with proper mats, spotting equipment and qualified spotters for each activity or skill. Use this equipment only for its intended purpose. Do not modify equipment in any way. Inspect each component for damage, loose fittings or signs of wear before each use. Do not use if you have any concern as to the condition of this equipment. Test unit for stability prior to each use. Do not use if you have any concern about the stability, condition or suitability of this equipment. Inspect warning labels and replace when marred or damaged. Before each subsequent use, re-check equipment stability and settings.

## INSTALLATION/ASSEMBLY TIPS

### FREE STANDING BALLET BARRE INSTALLATION (PAGE 2 OF 2)

READ THIS DOCUMENT AND ALL OTHER ACCOMPANYING PRODUCT DOCUMENTATION THOROUGHLY BEFORE INSTALLING, USING OR PERMITTING USE OF THIS EQUIPMENT. REQUIRE ALL PERSONS INTENDING TO USE THIS EQUIPMENT, AS WELL AS THOSE INSTRUCTING, ASSISTING OR COACHING OTHERS IN THE USE OF THIS PRODUCT, TO READ THIS DOCUMENT THOROUGHLY BEFORE AUTHORIZING THEM TO ENGAGE IN THOSE OR RELATED ACTIVITIES.

#### 2. DRILL HOLES IN WOOD BARRE FOR EXTENSIONS (Omit if pre-drilled wood barre is used.)

- Using a 3/8" drill and make all holes 7/8" deep (NO DEEPER).
- Using a 5/16" drill in the same hole, go down another 5/8" for a total depth of 1 1/2".
- IMPORTANT: These holes must be exactly parallel to each other and perpendicular to barre. (Using a drill press is recommended.)
- DO NOT DRILL THROUGH BARRE!**

#### 3. ATTACH EXTENSIONS TO WOOD BARRE

- Screw threaded end of extension into in Barre clockwise by hand until shoulders touch wood.
- An additional 1/2 turn (NO MORE) may be necessary to straighten out the brackets and make them perpendicular to the Wood Barre, and parallel to each other.
- Assemble wing nuts, washers, and square nuts exactly as shown in illustration below.

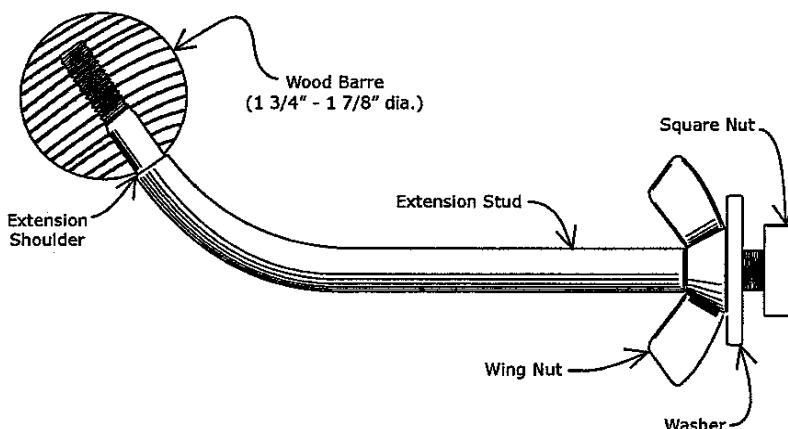

#### 4. MOUNT BARRE ASSEMBLY

- Lift barre assembly and slide the square nut on the ends of each extension into top slot of corresponding channel with washers and wing nuts outboard of channel.
- When barre is at your desired height, tighten wing nuts.
- To adjust barre, loosen wing nuts to permit barre to slide up and down in channel; retighten wing nut when barre is at desired height.
- Grab the wood barre near extensions and wiggle barre up and down when tightening and loosening the wing nuts.



### IMPORTANT CONSUMER PRODUCT HAZARD WARNING — PLEASE READ!

A possibility of serious injury, including paralysis or death, is inherent in any activity involving motion or height. Equipment with which this notice is included is intended for use only by properly trained, qualified persons under supervised conditions. Use without proper supervision is dangerous and should not be undertaken or permitted. Know your limitations as well as the limitations of your equipment. Consult a qualified instructor before attempting any new activity or skill. This equipment must be used with proper mats, spotting equipment and qualified spotters for each activity or skill. Use this equipment only for its intended purpose. Do not modify equipment in any way. Inspect each component for damage, loose fittings or signs of wear before each use. Do not use if you have any concern as to the condition of this equipment. Test unit for stability prior to each use. Do not use if you have any concern about the stability, condition or suitability of this equipment. Inspect warning labels and replace when marred or damaged. Before each subsequent use, re-check equipment stability and settings.